

# Classification of subfactors to index 5

## JMM, New Orleans

David Penneys

joint work with Izumi, Jones, Morrison, Peters, Snyder, Tener

University of California, Berkeley

January 8, 2011

# Subfactors

## Theorem [Jon83]

For a  $II_1$ -subfactor  $A \subset B$ ,

$$[B: A] \in \left\{ 4 \cos^2 \left( \frac{\pi}{n} \right) \mid n = 3, 4, \dots \right\} \cup [4, \infty].$$

## Definition

The Jones tower of  $A = A_0 \subset A_1 = B$  is given by

$$A_0 \subset A_1 \overset{e_1}{\subset} A_2 \overset{e_2}{\subset} A_3 \overset{e_3}{\subset} \dots$$

where  $e_i$  is the projection in  $B(L^2(A_i))$  with range  $L^2(A_{i-1})$ .

## The tower of relative commutants

$$\begin{array}{cccc}
 \vdots & \vdots & \vdots & \vdots \\
 \cup & \cup & \cup & \cup \\
 A'_0 \cap A_3 & \supset A'_1 \cap A_3 & \supset A'_2 \cap A_3 & \supset A'_3 \cap A_3 = \mathbb{C} \\
 \cup & \cup & \cup & \\
 A'_0 \cap A_2 & \supset A'_1 \cap A_2 & \supset A'_2 \cap A_2 = \mathbb{C} & \\
 \cup & \cup & & \\
 A'_0 \cap A_1 & \supset A'_1 \cap A_1 = \mathbb{C} & & \\
 \cup & & & \\
 A'_0 \cap A_0 = \mathbb{C} & & & 
 \end{array}$$

$A'_i \cap A_j \cong A'_{i+2} \cap A_{j+2}$  canonically.

## The tower of relative commutants

$$\begin{array}{ccc}
 \vdots & & \vdots \\
 \cup & & \cup \\
 A'_0 \cap A_3 & \supset & A'_1 \cap A_3 \\
 \cup & & \cup \\
 A'_0 \cap A_2 & \supset & A'_1 \cap A_2 \\
 \cup & & \cup \\
 A'_0 \cap A_1 & \supset & A'_1 \cap A_1 = \mathbb{C} \\
 \cup & & \\
 A'_0 \cap A_0 & = & \mathbb{C}
 \end{array}$$

$A'_i \cap A_j \cong A'_{i+2} \cap A_{j+2}$  canonically.

## The tower of relative commutants

$$\begin{array}{ccc}
 \vdots & & \vdots \\
 \cup & & \cup \\
 A'_0 \cap A_3 & \supset & A'_1 \cap A_3 \\
 \cup & & \cup \\
 A'_0 \cap A_2 & \supset & A'_1 \cap A_2 \\
 \cup & & \cup \\
 A'_0 \cap A_1 & \supset & A'_1 \cap A_1 = \mathbb{C} \\
 \cup & & \\
 A'_0 \cap A_0 & = & \mathbb{C}
 \end{array}$$

These two towers form a planar algebra.

# Planar algebras

## Definition [Jon99]

A planar algebra is a collection of (finite dimensional, complex) vector spaces  $P_\bullet$  together with an action of the planar operad  $Z: \mathbb{P} \rightarrow ML(P_\bullet)$ .

## Example

Planar diagrams give multilinear maps which compose nicely:

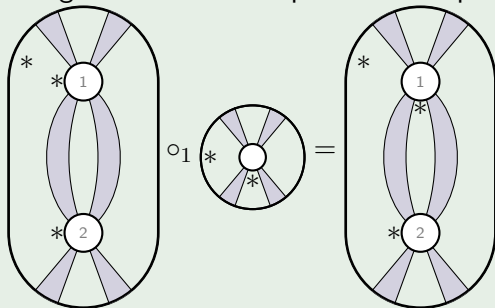

# Principal graphs

The relative commutants are all finite dimensional. The tower

$$A'_0 \cap A_0 \subset A'_0 \cap A_1 \subset A'_0 \cap A_2 \subset \dots$$

is described by its Bratteli diagram (and the trace).

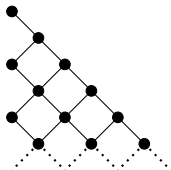

# Principal graphs

The relative commutants are all finite dimensional. The tower

$$A'_0 \cap A_0 \subset A'_0 \cap A_1 \subset A'_0 \cap A_2 \subset \dots$$

is described by its Bratteli diagram (and the trace).

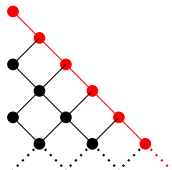

The non-reflected part is the principal graph.

# Paragroups

## Definition [Ocn88]

The paragroup of  $A \subset B$  is the 2-category given by

- 0-morphisms:  $\{A, B\}$
- 1-morphisms: bimodule summands of  $L^2(A_k)$  for some  $k \geq 0$
- 2-morphisms: intertwiners (summands of  $A'_0 \cap A_k$  and  $A'_1 \cap A_{k+1}$  for  $k \geq 0$ )

This 2-category is semi-simple, unitary, rigid (duals are well behaved), pivotal, sometimes spherical.

Planar diagrams give a graphical calculus which makes the paragroup have the structure of a shaded planar algebra.

# Fusion/ $C^*$ -tensor categories

## Definition

The even half of the paragroup of  $A \subset B$  (finite index) is the tensor category given by

- 0-morphisms:  $\{A\}$
- 1-morphisms:  $A - A$  bimodule summands of  $L^2(A_k)$  for some  $k \geq 0$
- 2-morphisms: intertwiners (summands of  $A'_0 \cap A_{2k}$  for  $k \geq 0$ )

The even half is a pivotal  $C^*$ -tensor category which forms an unshaded planar algebra.

## Definition

A fusion category is a semisimple, rigid tensor category with finitely many isomorphism classes of simple objects.

# Principal graphs revisited

Let  $X = {}_A L^2(B)_B$ .

## Definition

The principal graph has one vertex for each simple  ${}_A P_A$  and  ${}_A Q_B$ , and the number of edges connecting them is

$$\dim(\text{Hom}_{A-B}(P \otimes X, Q))$$

The dual principal graph has one vertex for each simple  ${}_B R_B$  and  ${}_B S_A$ , and the number of edges connecting them is

$$\dim(\text{Hom}_{B-A}(R \otimes X^*, S))$$

The dual principal graph of  $A_0 \subset A_1$  is the principal graph of  $A_1 \subset A_2$ .

For simplicity, we assume the (dual) principal graph is simply laced.

# Example: the Haagerup principal graph

 $A \text{Mod}_A$ 

 $A \text{Mod}_B$ 

Start with the trivial bimodule

$${}_A L^2(A)_A = {}_A L^2(A_0)_A.$$

This bimodule is obviously self-dual.

# Example: the Haagerup principal graph

 $A \text{Mod}_A$ 
 $A \text{Mod}_B$ 

Tensor with  $X$  and take summands

$${}_A L^2(A)_A \otimes X_B \cong_A L^2(B)_B =_A L^2(A_1)_B.$$

$A - B$  bimodules are dual to  $B - A$  bimodules (on the dual graph).

# Example: the Haagerup principal graph

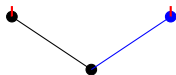
 $A \text{Mod}_A$ 
 $A \text{Mod}_B$ 

Tensor with  $X^*$  and take new summands

$${}_A L^2(B) \otimes X^* \cong_A L^2(A_2)_A.$$

If only one new bimodule appears, it must be self-dual.

# Example: the Haagerup principal graph

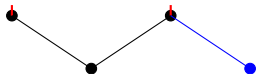
 $A \text{Mod}_A$ 
 $A \text{Mod}_B$ 

Tensor with  $X$  again and take new summands

$${}_A L^2(A_2)_A \otimes X_B \cong_A L^2(A_3)_B.$$

Once again, its dual is on the dual principal graph.

# Example: the Haagerup principal graph

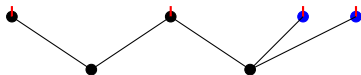
 $A \text{Mod}_A$ 
 $A \text{Mod}_B$ 

Tensor with  $X^*$  again and take new summands

$${}_A L^2(A_3) \otimes X^* \cong_A L^2(A_4)_A.$$

Here is an example of two self-dual bimodules at depth 4.

# Example: the Haagerup principal graph

 ${}_A \text{Mod}_A$ 
 ${}_A \text{Mod}_B$ 

Tensor with  $X$  again and take new summands

$${}_A L^2(A_4) \otimes X \cong_A L^2(A_5)_B.$$

Once again, the dual bimodules are on the dual principal graph.

# Example: the Haagerup principal graph

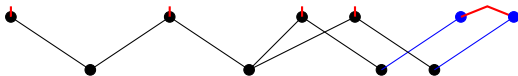
 $A \text{Mod}_A$ 
 $A \text{Mod}_B$ 

Tensor with  $X^*$  again and take new summands

$${}_A L^2(A_5) \otimes X^* \cong_A L^2(A_6)_A.$$

The final two bimodules are dual to each other.

## Classification up to index 4

## Theorem

Subfactors with index less than 4 are classified by their principal graphs (and a little more data):

- $A_n$
- $D_{2n}$
- $E_6$
- $E_8$

# Classification at index 4

## Theorem, Popa [Pop94]

Subfactors with index equal to 4 are classified by their principal graphs (and a little more data):

- $E_6^{(1)}$
- $E_7^{(1)}$
- $E_8^{(1)}$
- $A_{2n-1}^{(1)}$  ( $n \geq 1$ )
- $D_n^{(1)}$  ( $n \geq 4$ )
- $A_\infty^{(1)} = A_{\infty, \infty}$
- $A_\infty$
- $D_\infty$

Haagerup's classification to index  $3 + \sqrt{3}$ 

## Theorem, Haagerup [Haa94]

The principal graphs of a non- $A_\infty$  subfactor in the index range  $(4, 3 + \sqrt{3})$  is a translation of one of the following:

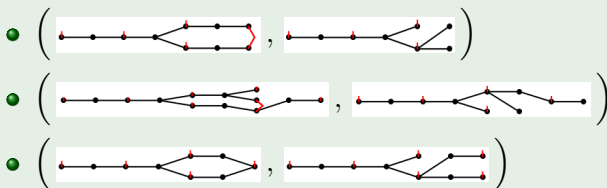

Asaeda-Yasuda eliminated translations by more than  $j = 4$  of the first family in [AY09].



Haagerup announced the elimination of translations by more than  $j = 2$  of the second family in [Haa94].

Bisch eliminated the third family in [Bis98].

## Main Theorem

## Theorem [MS, MPPS, IJMS, PT]

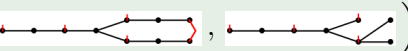
There are exactly 10 non- $A_\infty$  subfactors in the index range  $(4, 5)$ :

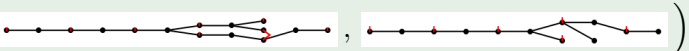
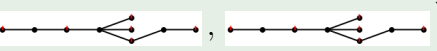
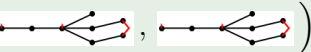
-  and its dual [AH99]
-   
and its dual [BMPS09]
-   
and its dual [AH99]
-  and its dual  
[GdlHJ89, Kaw95]
-  and its complex conjugate [Izu01]

# 4 parts of the proof

- 1 Part 1: the odometer
- 2 Part 2: triple points
  - Connections
  - Triple-single
  - Quadratic tangles
- 3 Part 3: quadruple points
- 4 Part 4: vines
  - Number theory
  - Eliminating vines

## Theorem, part 1 [MS]

The principal graph of any subfactor of index between 4 and 5 is a translate of one of an explicit finite list of graph pairs (which we call the vines), or is a translated extension of one of the following graph pairs (which we call the weeds).

$$C = \left( \text{[Diagram 1]}, \text{[Diagram 2]} \right),$$

$$F = \left( \text{[Diagram 3]}, \text{[Diagram 4]} \right),$$

$$B = \left( \text{[Diagram 5]}, \text{[Diagram 6]} \right),$$

$$Q = \left( \text{[Diagram 7]}, \text{[Diagram 8]} \right),$$

$$Q' = \left( \text{[Diagram 9]}, \text{[Diagram 10]} \right).$$

# The vines

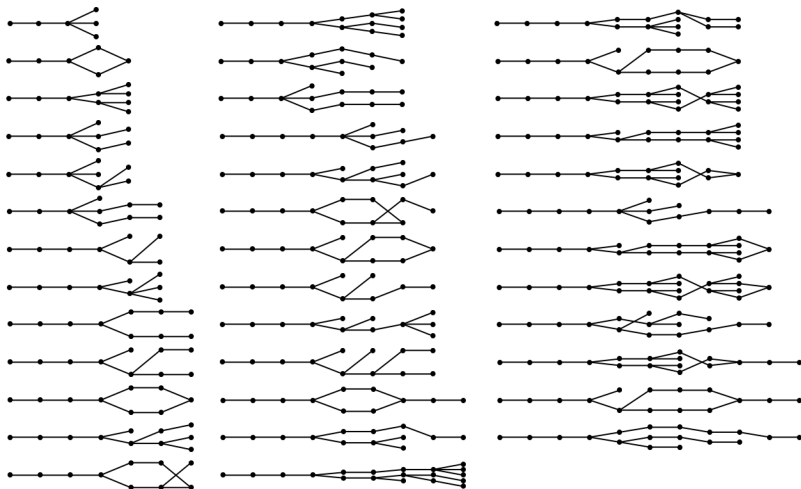

# Connections

Associativity of composing 1-morphisms (tensoring bimodules) means that we have natural isomorphisms

$$\mathrm{Hom}_{B-B}(X^* \otimes (P \otimes X), R) \cong \mathrm{Hom}_{B-B}((X^* \otimes P) \otimes X, R)$$

for (simples)  ${}_A P_A$  and  ${}_B R_B$ .

A connection records a change of (orthonormal) bases for these spaces.

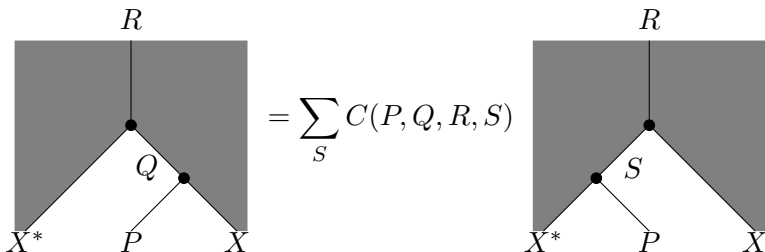

# Connections

Similarly, we have natural isomorphisms

$$\mathrm{Hom}_{B-A}(X^* \otimes (Q \otimes X^*), S) \cong \mathrm{Hom}_{B-B}((X^* \otimes Q) \otimes X^*, S)$$

for (simples)  ${}_A Q_B$  and  ${}_B S_A$ .

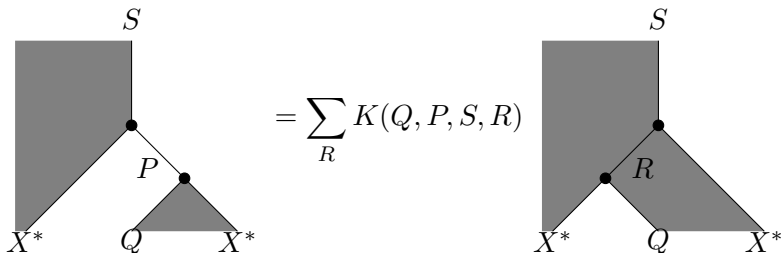

## Fact

$$\sqrt{\dim(P) \dim(R)} C(P, Q, R, S) = \sqrt{\dim(Q) \dim(S)} K(Q, P, S, R)$$

## Ocneanu's 4-partite graphs

The principal and dual principal graphs can be combined to form a 4-partite graph which records the fusion rules of the paragroup:

$$\begin{array}{ccccc}
 {}_A\text{Mod}_A & \xrightarrow{-\otimes_A X} & {}_A\text{Mod}_B & \xrightarrow{-\otimes_B X^*} & {}_A\text{Mod}_A \\
 \downarrow X^* \otimes_A - & & \downarrow X^* \otimes_A - & & \downarrow X^* \otimes_A - \\
 {}_B\text{Mod}_A & \xrightarrow{-\otimes_A X} & {}_B\text{Mod}_B & \xrightarrow{-\otimes_B X^*} & {}_B\text{Mod}_A
 \end{array}$$

The connection is the assignment of numbers to loops on this 4-partite graph.

# The Haagerup 4-partite graph

The Haagerup principal graphs

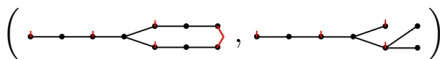

give the 4-partite graph

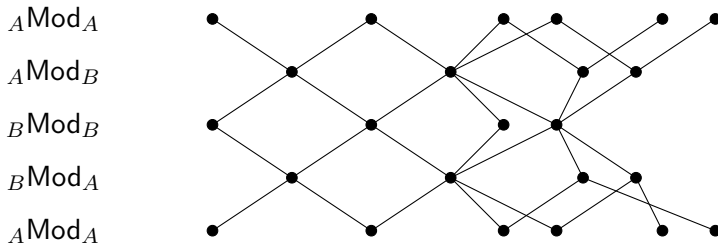

# The Haagerup 4-partite graph

The Haagerup principal graphs

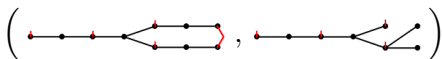

give the 4-partite graph

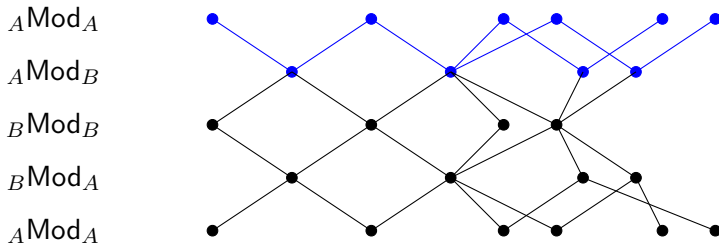

# The Haagerup 4-partite graph

The Haagerup principal graphs

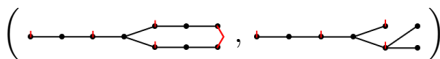

give the 4-partite graph

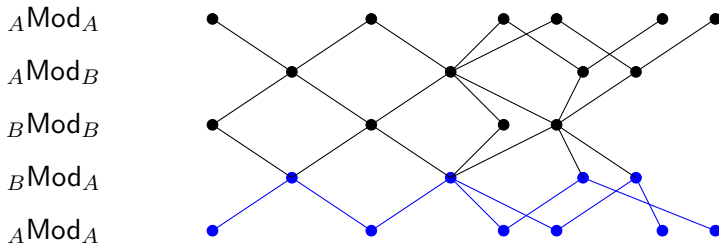

# The Haagerup 4-partite graph

The Haagerup principal graphs

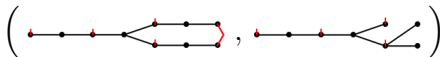

give the 4-partite graph

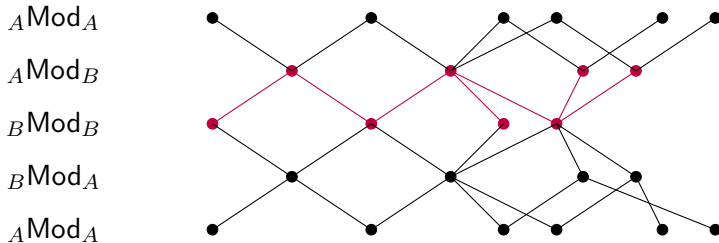

# The Haagerup 4-partite graph

The Haagerup principal graphs

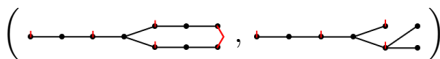

give the 4-partite graph

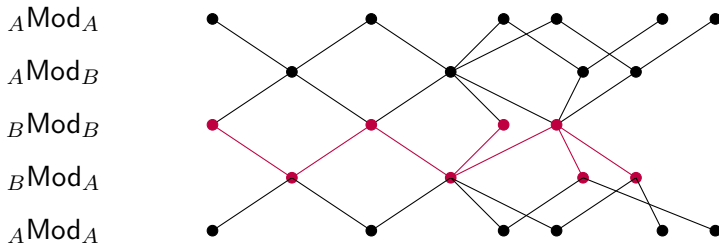

# The Haagerup 4-partite graph

The Haagerup principal graphs

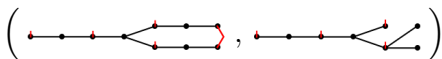

give the 4-partite graph

$A \text{Mod}_A$

$A \text{Mod}_B$

$B \text{Mod}_B$

$B \text{Mod}_A$

$A \text{Mod}_A$

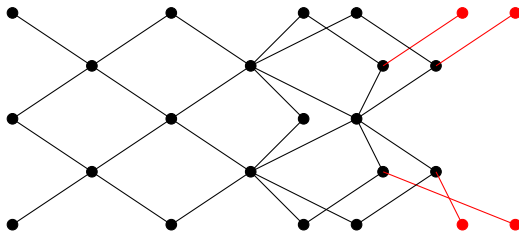

# Biunitarity

Given  ${}_A P_A$  and  ${}_B R_B$ , we get a unitary matrix  $C(P, -, R, -)$  where entries correspond to loops based at  $P$  through  $R$ .

Given  ${}_A Q_B$  and a  ${}_B S_A$ , we get a unitary matrix  $K(Q, -, S, -)$  where entries correspond to loops based at  $Q$  through  $S$ .

## Example 1

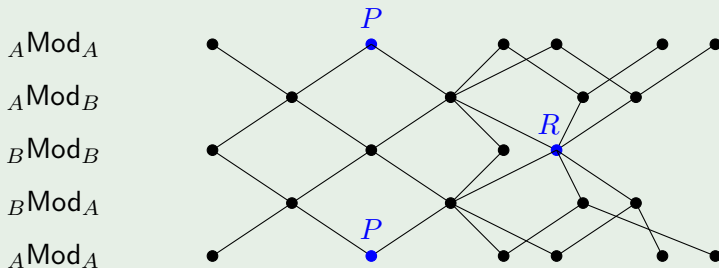

$$\sqrt{\dim(P) \dim(R)} C(P, Q, R, S) = \sqrt{\dim(Q) \dim(S)} K(Q, P, S, R)$$

# Biunitarity

Given  ${}_A P_A$  and  ${}_B R_B$ , we get a unitary matrix  $C(P, -, R, -)$  where entries correspond to loops based at  $P$  through  $R$ .

Given  ${}_A Q_B$  and a  ${}_B S_A$ , we get a unitary matrix  $K(Q, -, S, -)$  where entries correspond to loops based at  $Q$  through  $S$ .

## Example 1

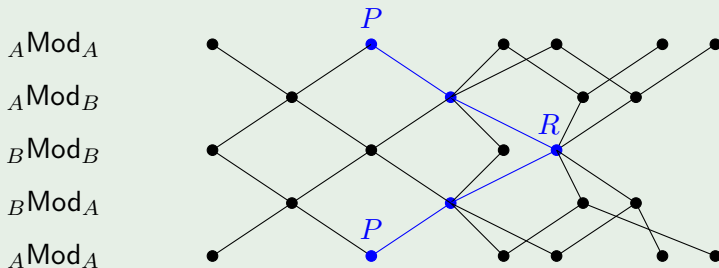

$$\sqrt{\dim(P) \dim(R)} C(P, Q, R, S) = \sqrt{\dim(Q) \dim(S)} K(Q, P, S, R)$$

# Biunitarity

Given  ${}_A P_A$  and  ${}_B R_B$ , we get a unitary matrix  $C(P, -, R, -)$  where entries correspond to loops based at  $P$  through  $R$ .

Given  ${}_A Q_B$  and  ${}_B S_A$ , we get a unitary matrix  $K(Q, -, S, -)$  where entries correspond to loops based at  $Q$  through  $S$ .

## Example 2

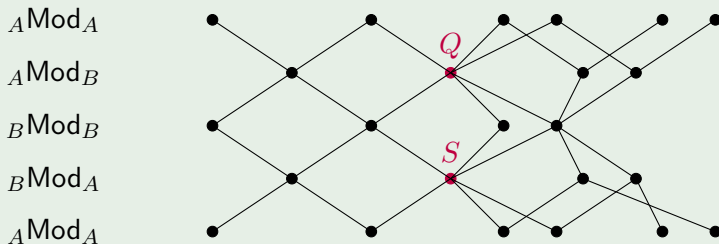

$$\sqrt{\dim(P) \dim(R)} C(P, Q, R, S) = \sqrt{\dim(Q) \dim(S)} K(Q, P, S, R)$$

# Biunitarity

Given  ${}_A P_A$  and  ${}_B R_B$ , we get a unitary matrix  $C(P, -, R, -)$  where entries correspond to loops based at  $P$  through  $R$ .

Given  ${}_A Q_B$  and  ${}_B S_A$ , we get a unitary matrix  $K(Q, -, S, -)$  where entries correspond to loops based at  $Q$  through  $S$ .

## Example 2

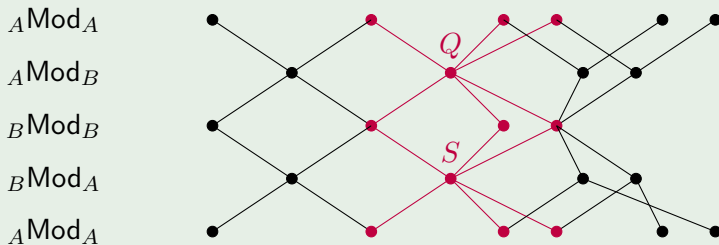

$$\sqrt{\dim(P) \dim(R)} C(P, Q, R, S) = \sqrt{\dim(Q) \dim(S)} K(Q, P, S, R)$$

## Ocneanu's obstruction

## Theorem (Ocneanu [Haa94])

Suppose the principal graphs of a subfactor have an initial triple point  $\beta, \beta^*$  (at an even depth)

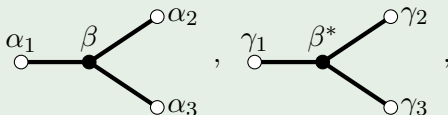

such that  $\dim(\alpha_i) = \dim(\gamma_i)$  for  $i = 1, 2, 3$  and

$$\dim(\text{Hom}(X^* \otimes \alpha_j \otimes X, \gamma_k)) = 1 \text{ for } j, k \in \{2, 3\}.$$

Then  $[B: A] \leq 4$ .

# Haagerup's Corollary

Corollary (Haagerup [Haa94], Jones [Jon10])

If a principal graph starts out like a translation by  $j$  of

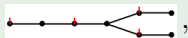

then the dual principal graph starts out like a translation by  $j$  of

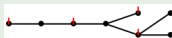

(and vice versa).

# Triple-single obstruction

## Theorem (weak form) [MPPS]

If the principal graphs of a subfactor start like a  $2k$  translation of

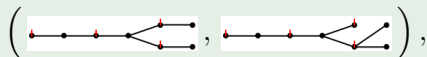

then  $|\dim(\alpha_2) - \dim(\alpha_3)| \leq 1$ .

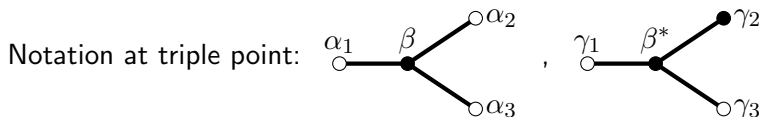

$$a_i = \sqrt{\dim(\alpha_i)}, \quad c_i = \sqrt{\dim(\gamma_i)}, \quad b = \sqrt{\dim(\beta)} = \sqrt{\dim(\beta^*)}$$

# Proof of the triple-single obstruction

## Proof

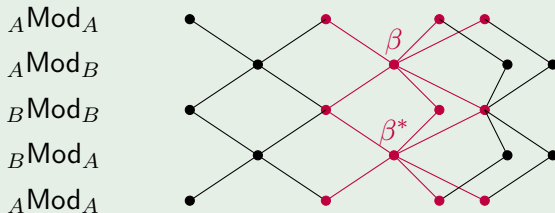

Find  $K(\beta, -, \beta^*, -) = \begin{pmatrix} ? & ? & ? \\ ? & ? & ? \\ ? & ? & ? \end{pmatrix}$

Label rows by  $\alpha$ 's ( $A - A$  bimodules) and columns by  $\gamma$ 's ( $B - B$  bimodules).

# Proof of the triple-single obstruction

## Proof

$A \text{ Mod } A$

$A \text{ Mod } B$

$B \text{ Mod } B$

$B \text{ Mod } A$

$A \text{ Mod } A$

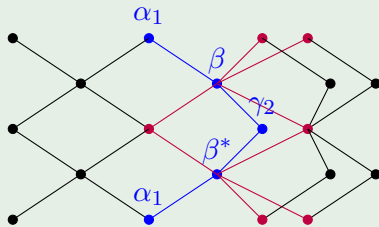

$$K(\beta, \alpha_1, \beta^*, \gamma_2) = \frac{a_1 c_2}{b^2} C(\alpha_1, \beta, \gamma_2, \beta^*)$$

$$\text{In modulus: } K(\beta, -, \beta^*, -) = \begin{pmatrix} ? & \frac{a_1 c_2}{b^2} & ? \\ ? & ? & ? \\ ? & ? & ? \end{pmatrix}$$

# Proof of the triple-single obstruction

## Proof

$A \text{ Mod } A$

$A \text{ Mod } B$

$B \text{ Mod } B$

$B \text{ Mod } A$

$A \text{ Mod } A$

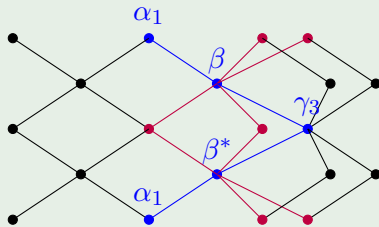

$$K(\beta, \alpha_1, \beta^*, \gamma_3) = \frac{a_1 c_3}{b^2} C(\alpha_1, \beta, \gamma_3, \beta^*)$$

$$\text{In modulus: } K(\beta, -, \beta^*, -) = \begin{pmatrix} ? & \frac{a_1 c_2}{b^2} & \frac{a_1 c_3}{b^2} \\ ? & ? & ? \\ ? & ? & ? \end{pmatrix}$$

# Proof of the triple-single obstruction

## Proof

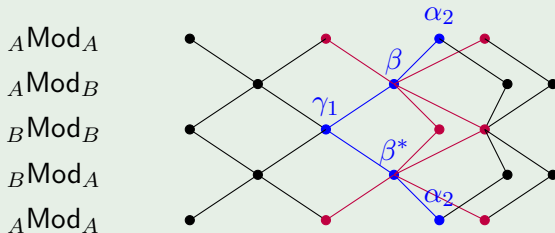

$$K(\beta, \alpha_2, \beta^*, \gamma_1) = \frac{a_2 c_1}{b^2} C(\alpha_2, \beta, \gamma_1, \beta^*)$$

$$\text{In modulus: } K(\beta, -, \beta^*, -) = \frac{1}{b^2} \begin{pmatrix} ? & a_1 c_2 & a_1 c_3 \\ a_2 c_1 & ? & ? \\ ? & ? & ? \end{pmatrix}$$

# Proof of the triple-single obstruction

## Proof

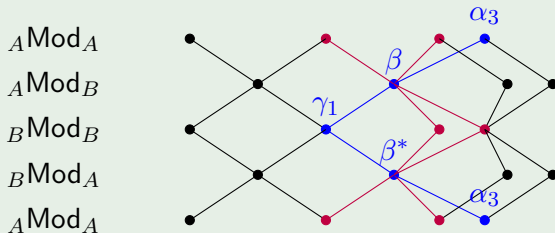

$$K(\beta, \alpha_3, \beta^*, \gamma_1) = \frac{a_3 c_1}{b^2} C(\alpha_3, \beta, \gamma_1, \beta^*)$$

In modulus:  $K(\beta, -, \beta^*, -) = \frac{1}{b^2} \begin{pmatrix} ? & a_1 c_2 & a_1 c_3 \\ a_2 c_1 & ? & ? \\ a_3 c_1 & ? & ? \end{pmatrix}$

# Proof of the triple-single obstruction

## Proof

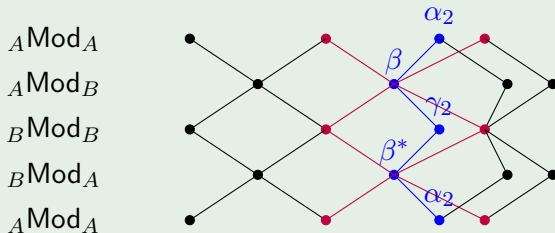

$$K(\beta, \alpha_2, \beta^*, \gamma_2) = \frac{a_2 c_2}{b^2} C(\alpha_2, \beta, \gamma_1, \beta^*)$$

In modulus:  $K(\beta, -, \beta^*, -) = \frac{1}{b^2} \begin{pmatrix} ? & a_1 c_2 & a_1 c_3 \\ a_2 c_1 & a_2 c_2 & ? \\ a_3 c_1 & ? & ? \end{pmatrix}$

# Proof of the triple-single obstruction

## Proof

$A \text{ Mod } A$

$A \text{ Mod } B$

$B \text{ Mod } B$

$B \text{ Mod } A$

$A \text{ Mod } A$

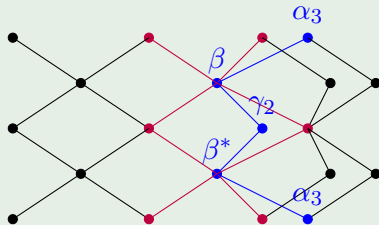

$$K(\beta, \alpha_2, \beta^*, \gamma_2) = \frac{a_3 c_2}{b^2} C(\alpha_2, \beta, \gamma_1, \beta^*)$$

In modulus:  $K(\beta, -, \beta^*, -) = \frac{1}{b^2} \begin{pmatrix} ? & a_1 c_2 & a_1 c_3 \\ a_2 c_1 & a_2 c_2 & ? \\ a_3 c_1 & a_3 c_2 & ? \end{pmatrix}$

# Proof of the triple-single obstruction

## Proof

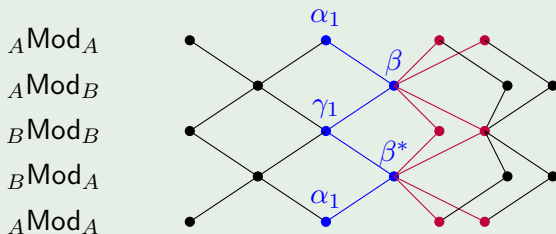

easy exercise:  $K(\beta, \alpha_1, \beta^*, \gamma_1) = \frac{1}{\dim(\beta)}$ .

In modulus:  $K(\beta, -, \beta^*, -) = \frac{1}{b^2} \begin{pmatrix} 1 & a_1 c_2 & a_1 c_3 \\ a_2 c_1 & a_2 c_2 & ? \\ a_3 c_1 & a_3 c_2 & ? \end{pmatrix}$

# Proof of the triple-single obstruction

## Proof

$$K(\beta, -, \beta^*, -) = \frac{1}{b^2} \begin{pmatrix} 1 & a_1 c_2 & a_1 c_3 \\ a_2 c_1 & a_2 c_2 & ? \\ a_3 c_1 & a_3 c_2 & ? \end{pmatrix}$$

where  $a_i = \sqrt{\dim(\alpha_i)}$ ,  $c_i = \sqrt{\dim(\gamma_i)}$ ,  $b = \sqrt{\dim(\beta)}$ , and  $a_1 = c_1$ .

Taking the inner product of the first two columns, we have

$$\lambda_1 \frac{a_1 c_2}{b^4} + \lambda_2 \frac{a_2^2 c_1 c_2}{b^4} + \lambda_3 \frac{a_3^2 c_1 c_2}{b^4} = 0$$

where  $\lambda_i$  has modulus 1.

# Proof of the triple-single obstruction

## Proof

$$K(\beta, -, \beta^*, -) = \frac{1}{b^2} \begin{pmatrix} 1 & a_1 c_2 & a_1 c_3 \\ a_2 c_1 & a_2 c_2 & ? \\ a_3 c_1 & a_3 c_2 & ? \end{pmatrix}$$

where  $a_i = \sqrt{\dim(\alpha_i)}$ ,  $c_i = \sqrt{\dim(\gamma_i)}$ ,  $b = \sqrt{\dim(\beta)}$ , and  $a_1 = c_1$ .

Taking the inner product of the first two columns, we have

$$\lambda_1 \frac{a_1 c_2}{b^4} + \lambda_2 \frac{a_2^2 c_1 c_2}{b^4} + \lambda_3 \frac{a_3^2 c_1 c_2}{b^4} = 0$$

where  $\lambda_i$  has modulus 1.

# Proof of the triple-single obstruction

## Proof

$$K(\beta, -, \beta^*, -) = \frac{1}{b^2} \begin{pmatrix} 1 & a_1 c_2 & a_1 c_3 \\ a_2 c_1 & a_2 c_2 & ? \\ a_3 c_1 & a_3 c_2 & ? \end{pmatrix}$$

where  $a_i = \sqrt{\dim(\alpha_i)}$ ,  $c_i = \sqrt{\dim(\gamma_i)}$ ,  $b = \sqrt{\dim(\beta)}$ , and  $a_1 = c_1$ .

Taking the inner product of the first two columns, we have

$$\lambda_1 \frac{a_1 c_2}{b^4} + \lambda_2 \frac{a_2^2 a_1 c_2}{b^4} + \lambda_3 \frac{a_3^2 a_1 c_2}{b^4} = 0$$

where  $\lambda_i$  has modulus 1.

# Proof of the triple-single obstruction

## Proof

$$K(\beta, -, \beta^*, -) = \frac{1}{b^2} \begin{pmatrix} 1 & a_1 c_2 & a_1 c_3 \\ a_2 c_1 & a_2 c_2 & ? \\ a_3 c_1 & a_3 c_2 & ? \end{pmatrix}$$

where  $a_i = \sqrt{\dim(\alpha_i)}$ ,  $c_i = \sqrt{\dim(\gamma_i)}$ ,  $b = \sqrt{\dim(\beta)}$ , and  $a_1 = c_1$ .

Taking the inner product of the first two columns, we have

$$\lambda_1 \frac{a_1 c_2}{b^4} + \lambda_2 \frac{a_2^2 a_1 c_2}{b^4} + \lambda_3 \frac{a_3^2 a_1 c_2}{b^4} = 0$$

where  $\lambda_i$  has modulus 1.

# Proof of the triple-single obstruction

## Proof

$$K(\beta, -, \beta^*, -) = \frac{1}{b^2} \begin{pmatrix} 1 & a_1 c_2 & a_1 c_3 \\ a_2 c_1 & a_2 c_2 & ? \\ a_3 c_1 & a_3 c_2 & ? \end{pmatrix}$$

where  $a_i = \sqrt{\dim(\alpha_i)}$ ,  $c_i = \sqrt{\dim(\gamma_i)}$ ,  $b = \sqrt{\dim(\beta)}$ , and  $a_1 = c_1$ .

Taking the inner product of the first two columns, we have

$$\lambda_1 + \lambda_2 a_2^2 + \lambda_3 a_3^2 = 0$$

where  $\lambda_i$  has modulus 1.

# Proof of the triple-single obstruction

## Proof

$$K(\beta, -, \beta^*, -) = \frac{1}{b^2} \begin{pmatrix} 1 & a_1 c_2 & a_1 c_3 \\ a_2 c_1 & a_2 c_2 & ? \\ a_3 c_1 & a_3 c_2 & ? \end{pmatrix}$$

where  $a_i = \sqrt{\dim(\alpha_i)}$ ,  $c_i = \sqrt{\dim(\gamma_i)}$ ,  $b = \sqrt{\dim(\beta)}$ , and  $a_1 = c_1$ .

Taking the inner product of the first two columns, we have

$$1 + \lambda_2 a_2^2 + \lambda_3 a_3^2 = 0$$

where  $\lambda_i$  has modulus 1.

# Proof of the triple-single obstruction

## Proof

$$K(\beta, -, \beta^*, -) = \frac{1}{b^2} \begin{pmatrix} 1 & a_1 c_2 & a_1 c_3 \\ a_2 c_1 & a_2 c_2 & ? \\ a_3 c_1 & a_3 c_2 & ? \end{pmatrix}$$

where  $a_i = \sqrt{\dim(\alpha_i)}$ ,  $c_i = \sqrt{\dim(\gamma_i)}$ ,  $b = \sqrt{\dim(\beta)}$ , and  $a_1 = c_1$ .

Taking the inner product of the first two columns, we have

$$1 + \lambda_2 \dim(\alpha_2) + \lambda_3 \dim(\alpha_3) = 0$$

where  $\lambda_i$  has modulus 1.

# Proof of the triple-single obstruction

## Proof

The equation

$$1 + \lambda_2 \dim(\alpha_2) + \lambda_3 \dim(\alpha_3) = 0$$

means that we have a triangle in the complex plane with sides of length 1,  $\dim(\alpha_2)$ , and  $\dim(\alpha_3)$ . Hence

$$|\dim(\alpha_2) - \dim(\alpha_3)| \leq 1.$$

# The Asaeda-Haagerup vine

## Theorem [Haa94, MPPS]

Translations by  $j > 0$  of

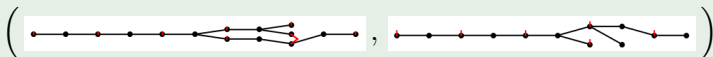

are not the principal graphs of a subfactor.

# The Asaeda-Haagerup vine

## Proof

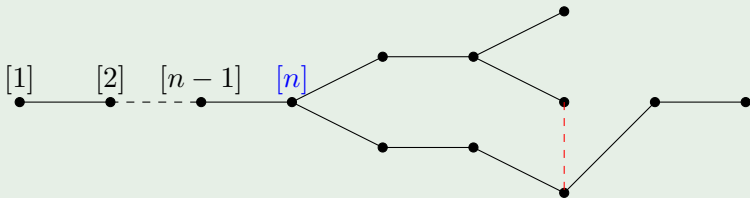

Show  $n \leq 6$ .

# The Asaeda-Haagerup vine

## Proof

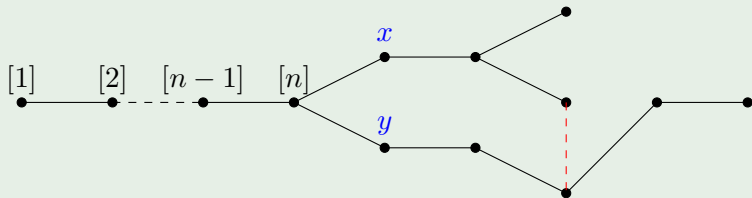

Find  $x, y$ .

# The Asaeda-Haagerup vine

## Proof

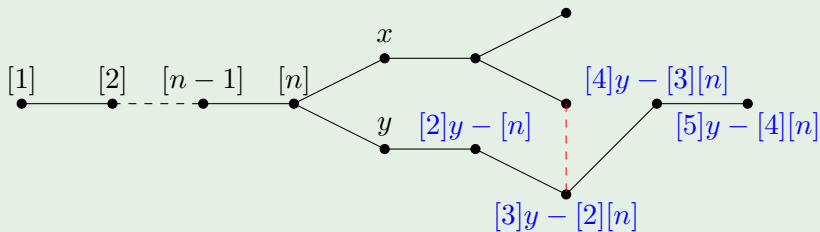

Find  $y$ .

# The Asaeda-Haagerup vine

## Proof

Note  $|x - y| \leq 1$  by the triple-single obstruction.

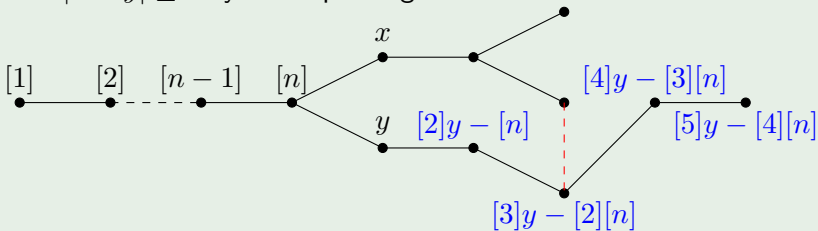

$$[6]y - [5][n] = 0 \text{ and } y = \frac{[5][n]}{[6]}.$$

# The Asaeda-Haagerup vine

## Proof

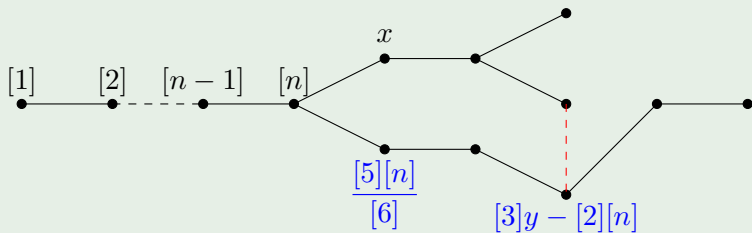

Find  $x$ .

# The Asaeda-Haagerup vine

## Proof

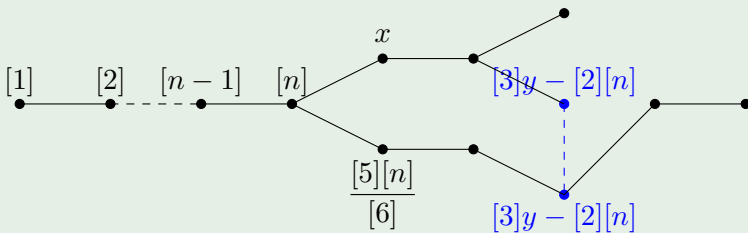

Find  $x$ .

# The Asaeda-Haagerup vine

## Proof

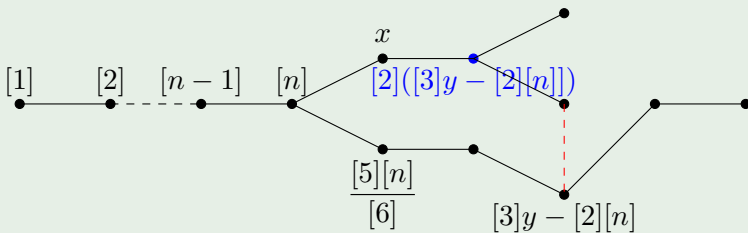

Find  $x$ .



# The Asaeda-Haagerup vine

## Proof

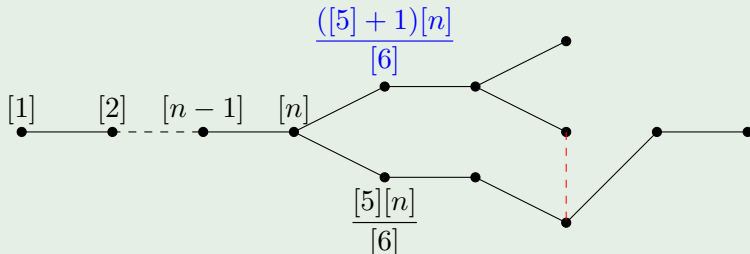

Recall  $|x - y| \leq 1$  by the triple-single obstruction.

# The Asaeda-Haagerup vine

## Proof

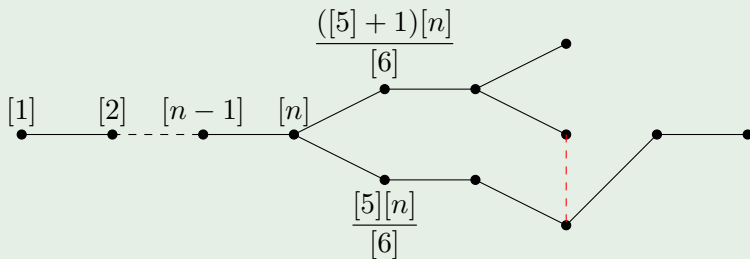

$$|x - y| = \left| \frac{([5] + 1)[n]}{[6]} - \frac{[5][n]}{[6]} \right| = \frac{[n]}{[6]} \leq 1.$$

So  $n \leq 6$ .

# Quadratic tangles obstruction

## Theorem

If the principal graphs of a subfactor start like a translation by  $j$  of

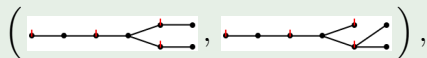

then  $j$  is even and

$$\frac{\dim(\alpha_2)}{\dim(\alpha_3)} + \frac{\dim(\alpha_3)}{\dim(\alpha_2)} = \frac{\lambda + \lambda^{-1} + 2}{[j + 4][j + 6]} + 2$$

where  $\lambda$  is a  $(j + 4)$ th root of unity called the chirality.

## Corollary

$$-4 \leq \left( \frac{\dim(\alpha_2)}{\dim(\alpha_3)} + \frac{\dim(\alpha_3)}{\dim(\alpha_2)} - 2 \right) [j + 4][j + 6] - 4 \leq 0$$

## Theorem, part 2 [MPPS]

Translated extensions of

$$C = \left( \text{Diagram 1}, \text{Diagram 2} \right) \text{ and}$$

$$B = \left( \text{Diagram 3}, \text{Diagram 4} \right)$$

are not the principal graphs of any subfactor. Translated extensions of

$$\mathcal{F} = \left( \text{Diagram 5}, \text{Diagram 6} \right)$$

are

- not principal graphs of subfactors in the index range  $(4, 5)$ ,
- not principal graphs of finite depth subfactors, and
- probably not principal graphs of any subfactor.

## Theorem, part 3 [IJMS]

The only translated extensions of

$$Q = \left( \text{Diagram 1}, \text{Diagram 2} \right) \text{ or}$$

$$Q' = \left( \text{Diagram 1}, \text{Diagram 2} \right)$$

which are the principal graphs of a subfactor are

$$\left( \text{Diagram 1}, \text{Diagram 2} \right)$$

## Proof.

The dual data is determined by a quadratic tangles argument. The translation and extension is determined by the connection at the quadruple point, where the  $4 \times 4$  unitary is completely determined by the information up to depth 2 past the branch point.

# Fusion categories

## Theorem [dBG91, CG94, ENO05]

If  $N \subset M$  is a finite depth subfactor, and  $\Gamma$  is its (dual) principal graph, then  $[M : N] = \|\Gamma\|^2$  [Pop90] is a cyclotomic integer.

## Theorem [Ost09]

The global dimension of a fusion category is an Ostrik  $d$ -number.

## Corollary

The global even dimension of a finite depth subfactor is an Ostrik  $d$ -number.

# How to kill vines

## Theorem [AY09]

Let  $\mathcal{H}_{4j}$  be the translate of  $\mathcal{H} =$   by  $4j$ . For  $j > 1$ ,  $\|\mathcal{H}_{4j}\|^2$  is not a cyclotomic integer, and thus  $\mathcal{H}_{4j}$  is not the principal graph of a subfactor.





## Theorem [CMS]

Given a vine  $(\Gamma, v)$ , there is an  $N(\Gamma)$  which is effectively computable such that for all  $j \geq N(\Gamma)$ ,  $\|\Gamma_j\|^2$  is not cyclotomic, where  $\Gamma_j$  is the translate of  $\Gamma$  at  $v$  by  $j$ . Hence  $\Gamma_j$  is not the principal graph of a subfactor for all  $j \geq N(\Gamma)$ .

# Eliminating the vines

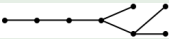
## Theorem, Part 4 [PT]

Of all the vines obtained in part 1, we get only 28 graphs with cyclotomic norm squared. Of these graphs, only the following graphs can occur as principal graphs of subfactors in the index range  $(4, 5)$ :

Vine	$N(\Gamma)$	$p$	Translates
	94	29,31	$j = 0$
	87	41,43	$j = 0, 4$
	89	41,43	$j = 0, 4$
	96	37,41	$j = 2$
	123	37,41	$j = 2$

# Thank you for listening!

Slides available at:





<http://math.berkeley.edu/~dpenneys>

Preprints available at:

Part 1: [arXiv:1007.1730](https://arxiv.org/abs/1007.1730)

Part 2: [arXiv:1007.2240](https://arxiv.org/abs/1007.2240)

Part 4: [arXiv:1010.3797](https://arxiv.org/abs/1010.3797)

-  Marta Asaeda and Uffe Haagerup, *Exotic subfactors of finite depth with Jones indices  $(5 + \sqrt{13})/2$  and  $(5 + \sqrt{17})/2$* , Comm. Math. Phys. **202** (1999), no. 1, 1–63, MR1686551 DOI:10.1007/s002200050574 arXiv:math.OA/9803044.
-  Marta Asaeda and Seidai Yasuda, *On Haagerup's list of potential principal graphs of subfactors*, Comm. Math. Phys. **286** (2009), no. 3, 1141–1157, MR2472028 DOI:10.1007/s00220-008-0588-0 arXiv:0711.4144.
-  Dietmar Bisch, *Principal graphs of subfactors with small Jones index*, Math. Ann. **311** (1998), no. 2, 223–231, MR1625762 DOI:http://dx.doi.org/10.1007/s002080050185.
-  Stephen Bigelow, Scott Morrison, Emily Peters, and Noah Snyder, *Constructing the extended Haagerup planar algebra*, 2009, arXiv:0909.4099, to appear *Acta Mathematica*.
-  Antoine Coste and Terry Gannon, *Remarks on Galois symmetry in rational conformal field theories*, Phys. Lett. B

**323** (1994), no. 3-4, 316–321, MR1266785  
DOI:10.1016/0370-2693(94)91226-2.



Frank Calegari, Scott Morrison, and Noah Snyder, *Cyclotomic integers, fusion categories, and subfactors*, With an appendix by Victor Ostrik. To appear in Communications in Mathematical Physics. arXiv:1004.0665.



Jan de Boer and Jacob Goeree, *Markov traces and  $II_1$  factors in conformal field theory*, Comm. Math. Phys. **139** (1991), no. 2, 267–304, MR1120140 euclid.cmp/1104203304.



Pavel Etingof, Dmitri Nikshych, and Viktor Ostrik, *On fusion categories*, Ann. of Math. (2) **162** (2005), no. 2, 581–642, MR2183279 DOI:10.4007/annals.2005.162.581 arXiv:math.QA/0203060.



Frederick M. Goodman, Pierre de la Harpe, and Vaughan F.R. Jones, *Coxeter graphs and towers of algebras*, Mathematical

Sciences Research Institute Publications, 14. Springer-Verlag, New York, 1989, x+288 pp. ISBN: 0-387-96979-9, MR999799.









Uffe Haagerup, *Principal graphs of subfactors in the index range  $4 < [M : N] < 3 + \sqrt{2}$* , Subfactors (Kyuzeso, 1993), World Sci. Publ., River Edge, NJ, 1994, MR1317352 available at <http://tqft.net/other-papers/subfactors/haagerup.pdf>, pp. 1–38.



Masaki Izumi, Vaughan F. R. Jones, Scott Morrison, and Noah Snyder, *Classification of subfactors of index less than 5, part 3: quadruple points*, In preparation.



Masaki Izumi, *The structure of sectors associated with Longo-Rehren inclusions. II. Examples*, Rev. Math. Phys. **13** (2001), no. 5, 603–674, MR1832764  
DOI:10.1142/S0129055X01000818.

-  Vaughan F. R. Jones, *Index for subfactors*, Invent. Math. **72** (1983), no. 1, 1–25, MR696688, DOI:10.1007/BF01389127.
-  \_\_\_\_\_, *Planar algebras I*, 1999, arXiv:math/9909027.
-  \_\_\_\_\_, *Quadratic tangles in planar algebras*, 2010, arXiv:1007.1158v2.
-  Yasuyuki Kawahigashi, *Classification of paragroup actions in subfactors*, Publ. Res. Inst. Math. Sci. **31** (1995), no. 3, 481–517, MR1355948. MR MR1355948 (96i:46077)
-  Scott Morrison, David Penneys, Emily Peters, and Noah Snyder, *Classification of subfactors of index less than 5, part 2: triple points*, arXiv:1007.2240.
-  Scott Morrison and Noah Snyder, *Subfactors of index less than 5, part 1: the principal graph odometer*, arXiv:1007.1730.
-  Adrian Ocneanu, *Quantized groups, string algebras and Galois theory for algebras*, Operator algebras and applications, Vol. 2,

London Math. Soc. Lecture Note Ser., vol. 136, Cambridge Univ. Press, Cambridge, 1988, MR996454, pp. 119–172.



Victor Ostrik, *On formal codegrees of fusion categories*, Math. Research Letters **16** (2009), no. 5, 895–901, arXiv:0810.3242.



Sorin Popa, *Classification of subfactors: the reduction to commuting squares*, Invent. Math. **101** (1990), no. 1, 19–43, MR1055708, DOI:10.1007/BF01231494.



\_\_\_\_\_, *Classification of amenable subfactors of type II*, Acta Math. **172** (1994), no. 2, 163–255, MR1278111, DOI:10.1007/BF02392646.



David Penneys and James Tener, *Classification of subfactors of index less than 5, part 4: vines*, arXiv:1010.3797.